

HXLR Encoder Mounting Instructions

Stegmann Encoder Model AG 626-XSR Siemens Encoder Model 6FX 2001 (Ranges 2" to 80", Adapter "D")

1. Remove 10-24 button head cap screw from barrel of module with 1/8" (.125") hex driver so that screw in shaft coupling may be accessed.
2. Place a .093" or 2.5 mm hex driver into the access hole for the coupling and seat into the coupling tightening screw. Back off the screw to remove any tension on the coupling.
3. Loosen four servo cleat mount screws with 3/32" (.093") hex driver so that the servo mounts may be rotated.
4. Remove o-ring from plastic bag and place into groove of encoder adapter plate on HXLR module.
5. Place Stegmann AG 626-XSR onto HXLR module so that shaft of encoder fits into coupling. Rotate servo cleats in place and tighten servo cleat screws to 8 lb-in.
6. Tighten screw in shaft coupling to 12 lb-in.
7. Loosen servo cleat screws to allow encoder to be rotated.
8. Rotate encoder to desired starting location and retighten servo cleat screws to 8 lb-in.
9. Re-install 10-24 button head cap screw into coupling access hole and tighten to 20 lb-in.

Dimensional Information

HXLR Module (Ranges to 80")

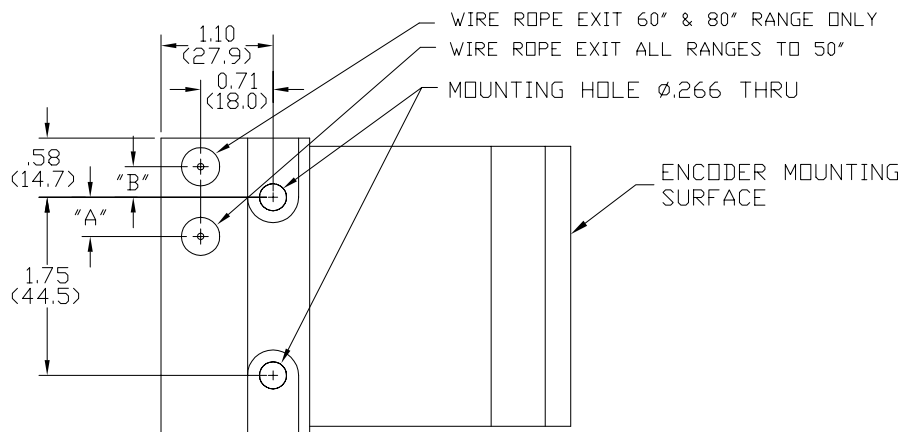

RANGE	"A"	"B"
2", 10"	.54 (13.7)	—
3", 15", 30"	.38 (9.6)	—
4", 20", 40"	.22 (5.6)	—
5", 25", 50"	.06 (1.5)	—
60"	—	.09 (2.3)
80"	—	.33 (8.4)

